

Pulse switching (20 pulses) model available in same shape.

- Detector
- Slide
- Push
- Rotary**
- Encoders
- Power
- Dual-in-line Package Type
- TACT Switch™

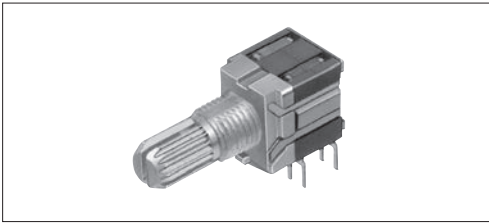

■ Typical Specifications

Items		Specifications	
		Rotary switch	Pulse Switch
Rating (max.) / (min.) (Resistive load)		0.1A 16V DC / 50μA 3V DC	
Contact resistance (Initial / After operating life)		50mΩ max. / 150mΩ max.	
Rotational torque		40±20 mN·m	15±7 mN·m
Operating life	Without load	10,000cycles	30,000cycles
	With load	10,000cycles (0.1A 16V DC)	

■ Product Line

Number of wafers	Poles	Positions	Changeover angle	Changeover timing	Actuator configuration	Actuator length (mm)	Minimum order unit (pcs.)		Product No.	Drawing No.			
							Japan	Export					
1	2	2	30±3°	Non shorting	18-tooth serration	L=15	200	1,600	SRBM120700	1			
					Flat				SRBM121300				
		3			18-tooth serration				L=20		150	1,200	SRBM131300
					Flat				L=15		200	1,600	SRBM131400
		4			18-tooth serration				L=20		150	1,200	SRBM140700
					Flat				L=20		150	1,200	SRBM140800
	1	5			18-tooth serration	L=15	200	1,600	SRBM150500				
					Flat				SRBM154002				
		6			18-tooth serration				SRBM160700				
					Flat				SRBM1L0800				
20 pulses	18±3°	—	18-tooth serration	L=15	200	1,600	SRBM1L1400	2					
			Flat										

Notes

1. Other varieties are also available. Please inquire.
2. All the axis are die casting shafts.

■ Packing Specifications

Bulk

Product No.	Number of packages (pcs.)		Export package measurements (mm)
	1 case / Japan	1 case / export packing	
SRBM120700 SRBM121300 SRBM131300 SRBM140700 SRBM150500 SRBM154002 SRBM160700 SRBM1L0800 SRBM1L1400	200	1,600	400 × 270 × 290
SRBM131400 SRBM140800 SRBM149501	150	1,200	

Refer to P.146 for shaft configurations.  
Refer to P.153 for soldering conditions.

## Dimensions

Single-shaft Type

Unit:mm

No.	Style	PC board mounting hole dimensions (Viewed from direction A)
1	<b>Rotary switch</b> 	
2	<b>Pulse switch</b> 	

## Pulse Switch Circuit Diagram

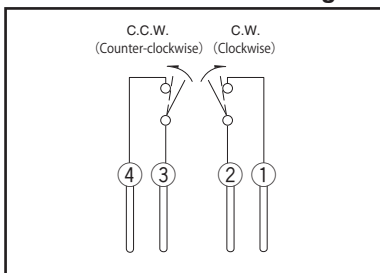

C.W. : ①② ON during changeover only  
 C.C.W. : ③④ ON during changeover only

## Rotary Switch Circuit Diagram (Viewed from Direction A of Below Diagram)

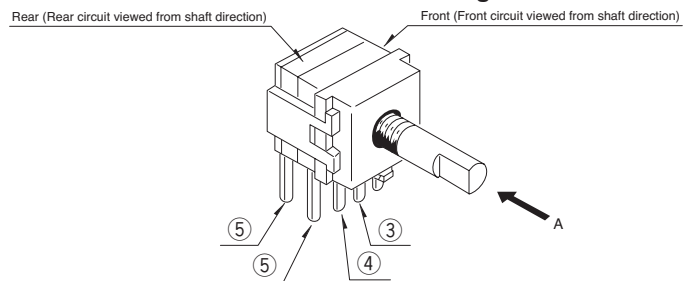

2 to 4-positions		5-positions ※ 1		6-positions ※ 2	
Rear	Front	Rear	Front	Rear	Front

## Notes

- For positions 2 to 4, 1 section consists of 2-poles.
- For positions 5 and 6, 1 section consists of 1-pole.
  - ※ 1: Circuit steps are positions 2 to 5 at front and positions 1 to 4 at rear. (External wiring to common terminal is required.)
  - ※ 2: Circuit steps are positions 3 to 6 at front and positions 1 to 4 at rear. (External wiring to common terminal is required.)

## Dummy Terminals

Number of positions	2	3	4	5	6
Front	④ ⑤	⑤	—	—	—
Rear	③ ④	④	—	—	—

- Detector
- Slide
- Push
- Rotary**
- Encoders
- Power
- Dual-in-line Package Type
- TACT Switch™

**18-tooth Serration Shaft**

The shaft shows the position in which it is turned fully counterclockwise.

**Die Casting Shaft**

Unit:mm

Shaft length L	ℓ
15	8
20	12

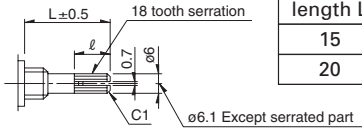

**Details About Serration**

- (1) The mold dimensions of standard serration and the dimensions of test jigs are as shown in the figure at left.
- (2) Position of the serration bottom  
When the shaft is turned fully counterclockwise, the position of the serration bottom is on the AA line.
- (3) Slitting angle  
The slitting angle (position) is not specified.

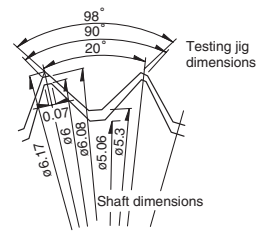

**Flat Shaft**

The shaft shows the position in which it is turned fully counterclockwise.

**Die Casting Shaft**

Unit:mm

Shaft length L	ℓ
15	7
20	12

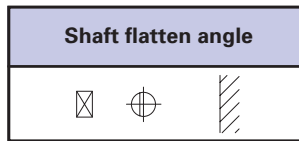
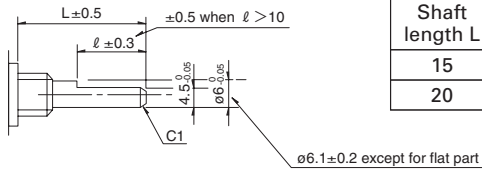

**Note**

SRBM Series are based on (printed terminal direction) .





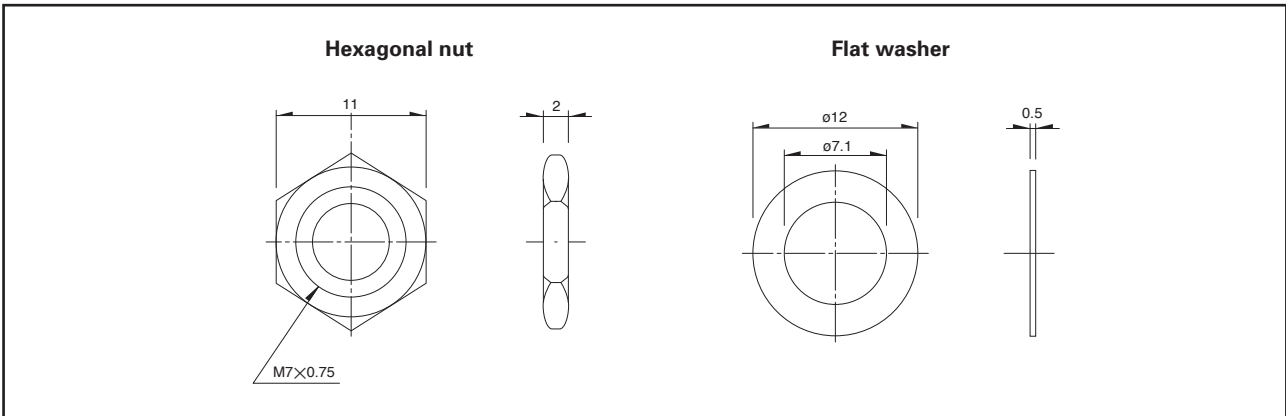









**Attached Parts**

Unit:mm



# Rotary Switches

## List of Varieties

Series	SRBD	SRBQ		SRBM		SRBV	SRRM	SRRN																																						
		Insertion	Reflow type	Rotary	Pulse																																									
Photo																																														
Angle of throw	36°	40±3°		30±3°	18±3°	30±3°																																								
Number of poles	1	1		1 2		1	1 2 3 4	2 3 4																																						
Rotational torque	13±5mN·m	6±3mN·m 13±5mN·m		40±20mN·m 15±7mN·m		30±15mN·m	80±30mN·m (Shoting) 70±30mN·m (Non shorting)	70±30mN·m																																						
Dimensions (mm)	W	11.4		10		16.2	—	—																																						
	D	12.4		12.5		18.5																																								
	H	3.5		11		7.5																																								
Operating temperature range	-25°C to +85°C	-10°C to +60°C		-30°C to +85°C		-10°C to +85°C	-10°C to +60°C	-30°C to +65°C																																						
Automotive use	—	—		●		—	—	—																																						
Life cycle																																														
Rating(max.)/(min.) (Resistive load)	1mA 5V DC 50 μA 3V DC	0.1A 16V DC 50 μA 3V DC				0.3A 16V DC 50 μA 3V DC	0.25A 30V DC 50 μA 3V DC	0.15A 12V DC 50 μA 3V DC																																						
Durability	Operating life without load	10,000cycles 250mΩ max.	10,000cycles 100mΩ max.		30,000 cycles 100mΩ max.	10,000cycles 100mΩ max.	10,000cycles 40mΩ max.	10,000cycles 70mΩ max.																																						
	Operating life with load Load as rating	10,000cycles 250mΩ max.	10,000cycles 100mΩ max.		10,000cycles 150mΩ max.		10,000cycles 60mΩ max.	10,000cycles 100mΩ max.																																						
Electrical performance	Initial contact resistance	200mΩ max.	50mΩ max.				20mΩ max.	50mΩ max.																																						
	Insulation resistance	100MΩ min. 100V DC					100MΩ min. 500V DC																																							
	Voltage proof	100V AC for 1minute					500V AC for 1minute																																							
Mechanical performance	Terminal strength	3N for 1minute	5N for 1minute				10N for 1minute	5N for 1minute																																						
	Actuator strength	Operating direction	—	—	0.5N·m	—	0.6N·m	1N·m																																						
		Pulling direction	50N	20N		100N																																								
	Wobble of actuator	<p>Load at the tip of shaft SRRM, SRBM, SRRN: 5N, SRBQ, SRBV: 1N</p> <p>The below table shows for SRRM, SRBM, SRRN (Unit: mm)</p> <table border="1" data-bbox="422 1563 737 1787"> <thead> <tr> <th>Measuring position from mounting surface</th> <th>Shaft wobble (max. value)</th> <th>Applicable mounting dimension</th> </tr> </thead> <tbody> <tr><td>10</td><td>0.17</td><td>15</td></tr> <tr><td>15</td><td>0.25</td><td>20</td></tr> <tr><td>20</td><td>0.35</td><td>25</td></tr> <tr><td>25</td><td>0.42</td><td>30</td></tr> <tr><td>30</td><td>0.5</td><td>above 35</td></tr> </tbody> </table> <p>The below table shows for SRBQ (Unit: mm)</p> <table border="1" data-bbox="774 1563 1034 1720"> <thead> <tr> <th>Distance from mounting surface to the tip of shaft</th> <th>Shaft wobble (max. value)</th> </tr> </thead> <tbody> <tr><td>below 5</td><td>0.5</td></tr> <tr><td>above 5 and below 10</td><td>0.9</td></tr> <tr><td>above 10 and below 15</td><td>1.2</td></tr> </tbody> </table> <p>The below table shows for SRBV (Unit: mm)</p> <table border="1" data-bbox="1070 1563 1385 1720"> <thead> <tr> <th>Measuring position from mounting surface</th> <th>Shaft wobble (max. value)</th> <th>Applicable mounting dimension</th> </tr> </thead> <tbody> <tr><td>10</td><td>0.2</td><td>15</td></tr> <tr><td>15</td><td>0.3</td><td>20</td></tr> <tr><td>20</td><td>0.4</td><td>25</td></tr> </tbody> </table>								Measuring position from mounting surface	Shaft wobble (max. value)	Applicable mounting dimension	10	0.17	15	15	0.25	20	20	0.35	25	25	0.42	30	30	0.5	above 35	Distance from mounting surface to the tip of shaft	Shaft wobble (max. value)	below 5	0.5	above 5 and below 10	0.9	above 10 and below 15	1.2	Measuring position from mounting surface	Shaft wobble (max. value)	Applicable mounting dimension	10	0.2	15	15	0.3	20	20	0.4
Measuring position from mounting surface	Shaft wobble (max. value)	Applicable mounting dimension																																												
10	0.17	15																																												
15	0.25	20																																												
20	0.35	25																																												
25	0.42	30																																												
30	0.5	above 35																																												
Distance from mounting surface to the tip of shaft	Shaft wobble (max. value)																																													
below 5	0.5																																													
above 5 and below 10	0.9																																													
above 10 and below 15	1.2																																													
Measuring position from mounting surface	Shaft wobble (max. value)	Applicable mounting dimension																																												
10	0.2	15																																												
15	0.3	20																																												
20	0.4	25																																												
Environmental performance	Cold	-40±2°C for 500h	-20±2°C for 96h	-40±2°C for 96h		-20±2°C for 96h		-40±2°C for 96h																																						
	Dry heat	85±2°C for 500h	85±2°C for 96h																																											
	Damp heat	60±2°C, 90 to 95%RH for 500h	40±2°C, 90 to 95%RH for 96h																																											
Page	140	142	144	147	149	151																																								

- Rotary Switches Soldering Conditions . . . . . 153
- Rotary Switches Cautions . . . . . 154

**Note** ● indicates applicability to all products in the series.

Detector  
Slide  
Push  
**Rotary**  
Encoders  
Power  
Dual-in-line Package Type  
TACT Switch™

# Rotary Switches Soldering Conditions

## Example of Reflow Soldering Condition

1. Heating method: Double heating method with infrared heater.
2. Temperature measurement: Thermocouple 0.1 to 0.2 φ CA (K) or CC (T) at soldering portion (copper foil surface).  
A heat resisting tape should be used for fixed measurement.
3. Temperature profile

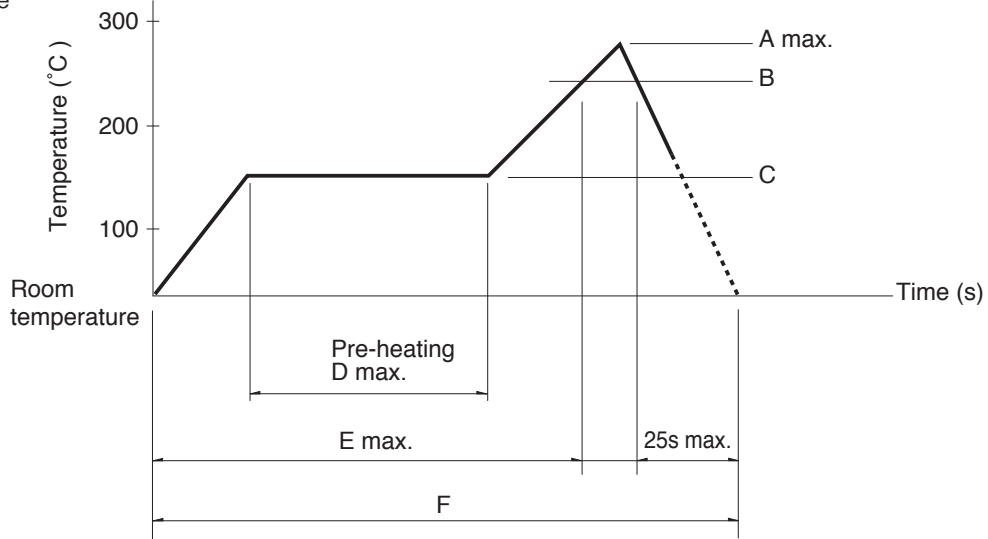

Series (Reflow type)	A (°C) 3s max.	B (°C)	C (°C)	D (s)	E (s)	F (s)
SRBQ	250	200	150±5	80 to 100	—	—

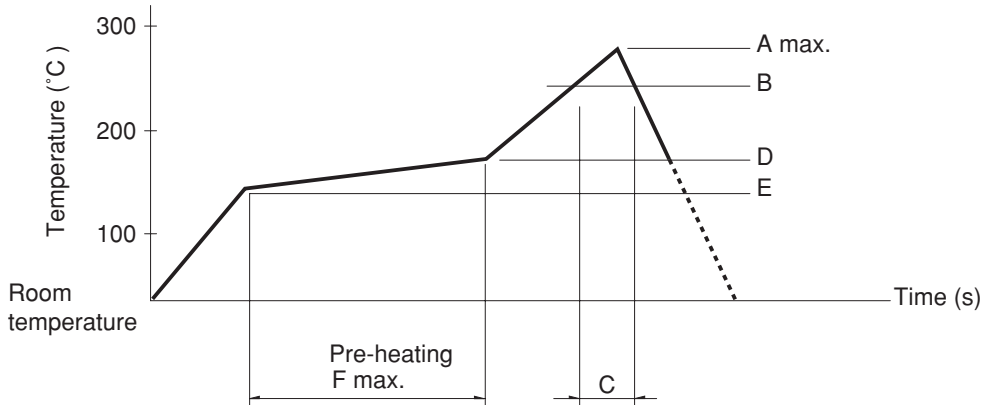

Series (Reflow type)	A (°C) 3s max.	B (°C)	C (s)	D (°C)	E (°C)	F (s)
SRBD	260	230	40	180	150	120

- Notes**
1. The condition mentioned above is the temperature on the mounting surface of a PC board. There are cases where the PC board's temperature greatly differs from that of the switch, depending on the PC board's material, size, thickness, etc. The above-stated conditions shall also apply to switch surface temperatures.
  2. Soldering conditions differ depending on reflow soldering machines. Prior verification of soldering condition is highly recommended.

## Reference for Hand Soldering

Series	Soldering temperature	Soldering time
SRBQ, SRBM, SRBV, SRRM, SRRN	350±10°C	3+1/0s
SRBQ (Reflow type)	350±10°C	3s max.

## Reference for Dip Soldering

(For PC board terminal types)

Series	Items		Dip soldering	
	Preheating temperature	Preheating time	Soldering temperature	Duration of immersion
SRBM	100°C max.	60s max.	260±5°C	5s max.
SRBV, SRRM, SRRN	—	—	260±5°C	10±1s
SRBQ	—	—	260±5°C	5±1s